

Temposonics®

Magnetostrictive, Absolute, Non-contact
Linear-Position Sensors

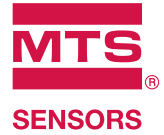

E-Series Model ER Analog and Start/Stop Outputs

Document Part Number:
550996 Revision F

Data Sheet



Model ER position sensor-
Stroke Length: 50 mm to 1500 mm (2 in. to 60 in.)

FEATURES

- Linear, Absolute Measurement
- Non-Contact Sensing Technology
- Linearity Deviation Less Than 0.02% F.S.
- Repeatability Within 0.005% F.S.
- Two Outputs Available:
 - Analog (Voltage/Current) Forward or Reverse Acting
 - Start/Stop Outputs
- Simple Sensor Parameter Upload (for Start/Stop)
- Stroke Length Range: 50 mm to 1500 mm (2 in. to 60 in.)
- Internal Electronics are Sealed for IP67 Ingress Protection
- EMI Shielded and CE Certified

BENEFITS

- Rugged, Cost Effective, Precise and Durable Non-wear Alternative to Linear Potentiometers
- Extendable and Retractable Dual Rod Ends
- The Magnet is Contained and Protected Inside The Sensor Housing
- Over Voltage Protection to 36 Vdc and Polarity Protection up to -30 Vdc

APPLICATIONS

- Continuous Operation In Harsh Industrial Conditions

TYPICAL INDUSTRIES

- Factory Automation
- Woodworking and Metal Forming
- Material Handling and Packaging

E-Series
Model ER



E-Series Model ER Sensor, Analog and Start/Stop Outputs

Product Overview and Specifications

Product overview

MTS Sensors continues to establish new performance standards for low-cost, fully-industrial, durable position sensors using the widely preferred magnetostrictive technology. This principle for accurate and non-contact measurement of linear-position sensing was developed 30 years ago by MTS and is used with outstanding success in a large variety of industrial applications. The innovative Temposonics model ER sensor brings proven benefits of magnetostrictive feedback to the versatile rod-and-cylinder sensor package.

It is ideal for demanding industrial applications where high performance non-contact feedback is essential for maximum productivity and overall reliability. The model ER sensor's rod-and-cylinder design has a rod that can extend from the sensor housing. As the rod is extended and retracted, the sensing magnet remains completely contained and protected at all times, ensuring reliable sensor performance in the toughest industrial environments.

Product specifications

Parameters	Specifications	Parameters	Specifications
OUTPUT		ENVIRONMENTAL	
Measured output variables:	Position	Operating conditions:	Operating temperature: -40 °C (-40 °F) to 75 °C (167 °F)
Resolution:	Analog: Infinite (restricted by output ripple) Start/Stop: 0.1, 0.01 and 0.005 mm (controller dependent)		Relative humidity: 90% no condensation
Linearity deviation:	< ± 0.02% full stroke (minimum ± 60 µm)		Ingress protection: IP 67** (when mating connector is correctly fitted)
Repeatability:	< ± 0.005% full stroke (minimum ± 20 µm)	EMC test:	Electromagnetic emission: EN 61000-6-4
Outputs:	Analog (voltage or current) Voltage: 0 to 10 Vdc and 10 to 0 Vdc or Two outputs: 0 to 10 Vdc and 10 to 0 Vdc (controller input resistance RL ≥ 5k Ohm) Current: 4 to 20 mA or 20 to 4 mA (Controller input resistance RL ≤ 500 Ohm)		Electromagnetic susceptibility: EN 61000-6-2. This sensor meets the requirements of the EC directives and is marked with CE.
	Digital-pulse (Start/Stop): RS-422 differential signal Serial parameter upload available for: Measuring range, offset, gradient, status and manufacturer number	Shock rating:	100 g (single hit)/ IEC standard EN 60068-2-27
Stroke length:	Range: 50 mm to 1500 mm (2 in. to 60 in.)	Vibration rating:	10 g/10 to 2000 Hz, IEC standard EN 60068-2-6 (resonance frequencies excluded)
ELECTRONICS		WIRING	
Operating voltage:	+24 Vdc nominal: -15% or +20%* Polarity protection: up to -30 Vdc Over voltage protection: up to 36 Vdc Current drain: Analog: 50 - 140 mA Start/Stop: 50 - 100 mA (Stroke length dependent) Dielectric withstand voltage: 500 Vdc (DC ground to machine ground)	Connection types:	Analog output: 5-pin (M12) male integral connector Start/Stop output: 8-pin (M12) male integral connector
		ROD-AND-CYLINDER STYLE SENSOR	
		Sensor rod:	Aluminum
		Sensor housing:	Aluminum
		Mounting options:	Adjustable mounting clamps or dual rod ends

* UL Recognition requires an approved power supply with energy limitation (UL 61010-1), or Class 2 rating according to the National Electrical Code (USA) / Canadian Electrical Code.

** The IP rating is not part of the UL Recognition.

Outputs

ANALOG (VOLTAGE/CURRENT) OUTPUTS

Analog outputs include voltage (0 to 10 Vdc forward or reverse acting), and current (4 to 20 mA forward or reverse acting). Since the outputs are direct, no signal conditioning electronics are needed when interfacing with controllers or meters (see 'Figure 1').

Analog output voltages ranges:

- 0 to 10 Vdc
- 10 to 0 Vdc
- 0 to 10 Vdc and 10 to 0 Vdc
- 4 to 20 mA
- 20 to 4 mA

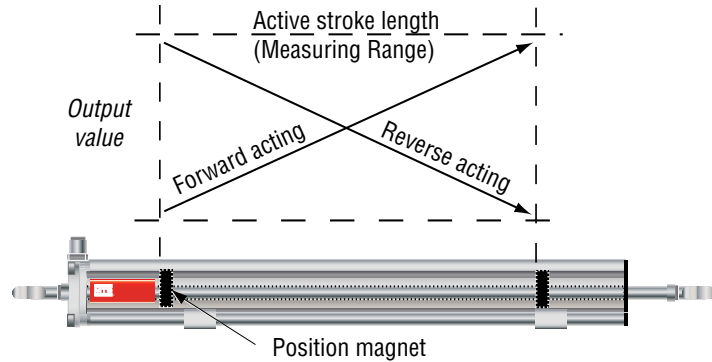

Figure 1. Analog Output signals

DIGITAL START/STOP OUTPUT

The Temposonics E-Series Model ER Start/Stop output sensors require a start signal from a controller or interface module to initiate the measurement cycle. The sensor generates a stop signal at the end of the measurement cycle that is used to stop the controller's counter clock.

The elapsed time between the Start and Stop signals is directly proportional to the magnet's position along the active stroke length. The controller can calculate the absolute position of the magnet from the time value and the sensor's unique gradient value (inverse of the speed for the sonic pulse traveling in the sensor's waveguide). (see 'Figure 2').

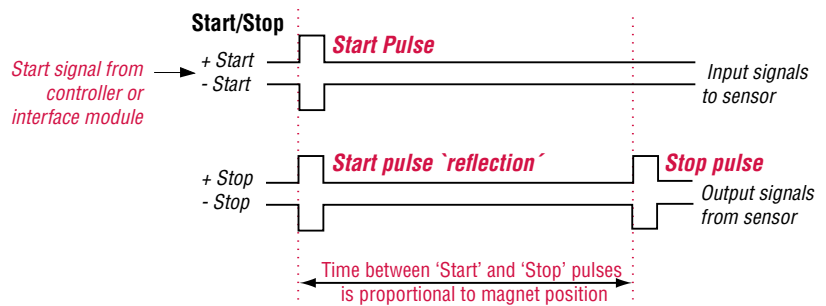

Figure 2. Start/Stop output signals (RS-422 differential pairs)

E-Series
Model ER

Communication

SENSOR PARAMETER UPLOAD FEATURE

For applications using smart sensor interfaces, the Model ER sensor with Start/Stop output (Option R3) comes with the ability to perform sensor parameter uploads. This feature replaces the task of entering sensor data manually, saving time and preventing possible entry errors during start-up or for system maintenance.

Note: Start/Stop output (option R3)

When the sensor parameter upload feature is not activated the Start/Stop output (Option R3) remains fully compatible with the Start/Stop output (Option R0) used in the previous generation E-Series sensor family.

The upload feature supports the following sensor parameters:

- Measuring range
- Offset
- Gradient - (Shown as speed of the sonic-strain pulse (m/s) or inverse speed (μs/in.))
- Status
- Manufacturer number

The sensor's specific parameters can be retrieved by the controller and interface module at any time, via the sensor's Start/Stop signal lines.

The sensor parameter upload feature requires a customer supplied RS-422 interface. The data format is serial, 4800 Baud, 8-bit data length. Please contact the factory for additional parameter upload protocol details.

E-Series Model ER Sensor, Analog and Start/Stop Outputs Sensor Dimensions, Connections and Wiring

Model ER rod-and-cylinder sensor dimension references

Drawings are for reference only, contact applications engineering for tolerance specific information.

A robust aluminum extrusion forms the sensor housing containing the sensor rod, magnet, sensing element and electronics. The permanent magnet is mounted on a sliding carrier attached to the end of the rod. As the rod moves in and out, the magnet travels above the sensing element inside the sensor housing.

MODEL ER ROD-AND-CYLINDER SENSOR

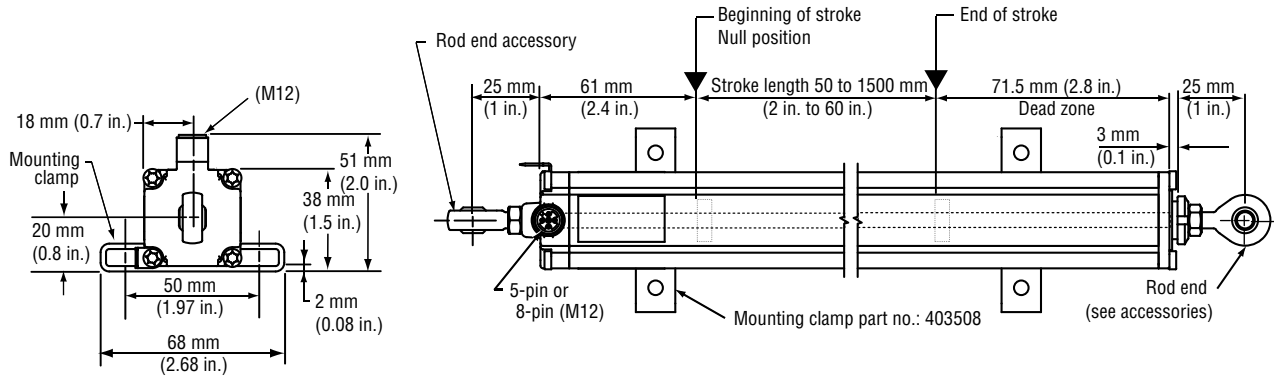

Figure 3. E-Series model ER rod-and cylinder sensor dimension reference

Connections and wiring (Model ER)

SENSOR INTEGRAL CONNECTOR (D34 AND D84) PINOUT/WIRE COLOR CODES

The E-Series model ER sensor connects directly to a controller or interface module with the standard male, 5-pin or 8-pin integral connector and an extension cable as described in 'Table 1' and 'Table 2' below.

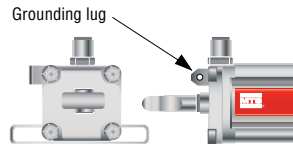

Figure 4. Grounding lug location.

Attention:

The sensors aluminum housing has an anodic coating which prevents the sensor's mounting clamps from providing the appropriate grounding. A grounding lug (see 'Figure 4') is provided near the connector end of the sensor for a convenient connection to earth ground. The appropriate grounding of the cable shield is also required at the controller end.



Integral D34 connector (male) as viewed from the end of the sensor

Pin no.	Extension Cable Wire color	Signal/Function Analog outputs
1	Brown	+24 Vdc
2	White	Output signal
3	Blue	DC ground (for power return)
4	Black	2nd Output signal (optional)
5	Gray	Ground for signal return

Table 1. Integral D34 sensor connector
(mates with cable connectors 370618 and 370619)



Integral D84 connector (male) as viewed from the end of the sensor

Pin no.	Extension cable wire color	Signal/function Start/Stop outputs
1	White	(+) Start
2	Brown	(-) Start
3	Green	(+) Stop
4	Yellow	(-) Stop
5	Gray	No connection
6	Pink	No connection
7	Blue	+24 Vdc
8	Red	DC ground (for power return)

Table 2. Integral D84 sensor connector
(mates with cable connectors 370671 and 370672)

E-Series Model ER Sensor, Analog and Start/Stop Outputs Ordering Information

Use the order matrix below to configure your Model ER sensor order number.

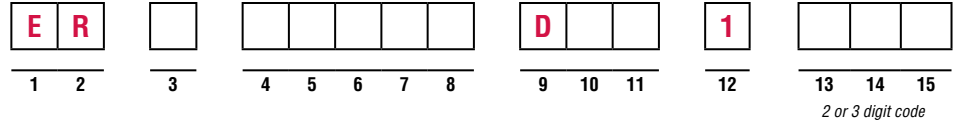

- SENSOR MODEL** _____ = E R **1 - 2**
- ER** = E-Series model ER position sensor
- HOUSING STYLE** _____ = **3**
- S** = Inside thread 1/4 - 28 at end of rod
- M** = Inside thread M6 at end of rod
- STROKE LENGTH** _____ = **4 - 8**
- _____ **M** = Millimeters (Encode in 25 or 50 mm increments) as indicated in 'Stroke length notes' below.
- _____ **U** = Inches (Encode in 1 or 2 in. increments) as indicated in 'Stroke length notes' below.
(Digit for tenths of inches is always '0')

Stroke length Notes:

Stroke length ranges:

M = 50 to 1500 mm (Preferred stroke lengths are: 75, 100, 150, 200, 300, 400, 500, 600, 750, 1000 and 1250 mm)

U = 2 to 60 in. (Preferred stroke lengths are: 3, 6, 9, 12, 15, 18, 21, 24, 30, 36, 42, 48 and 54 in.)

The increment size between standard stroke lengths vary as shown below:

Stroke length (mm)	Ordering increment
≤ 500 mm	25 mm
> 500 mm and ≤ 1500 mm	50 mm
Stroke length (IN)	Ordering increment
≤ 22 in.	1 in.
> 22 in. and ≤ 60 in.	2 in.

- SENSOR CONNECTION TYPES** _____ = D **9 - 11**
- D34** = 5-Pin (M12), male, (Analog output)
- D84** = 8-Pin (M12), male, (Start/Stop output)
- INPUT VOLTAGE** _____ = 1 **12**
- 1** = + 24 Vdc (+20%, -15%), standard
- OUTPUT** (2 or 3 digit code defined by output option selected below) _____ = **13 - 15**
- VOLTAGE**
- V01** = 0 to 10 Vdc
- V11** = 10 to 0 Vdc
- V03** = 0 to 10 Vdc and 10 to 0 Vdc (2 output channels)
- CURRENT**
- A01** = 4 to 20 mA
- A11** = 20 to 4 mA
- START/STOP**
- R3** = Start/Stop with sensor parameters upload function
- Start/Stop output (Option **R3**) is fully compatible with the Start/Stop output (Option **R0**) used in the previous generation E-Series sensors.

**E-Series
Model ER**

